

ELEVATION
(REQUIRED CONCRETE= 3.4 CU. YDS)

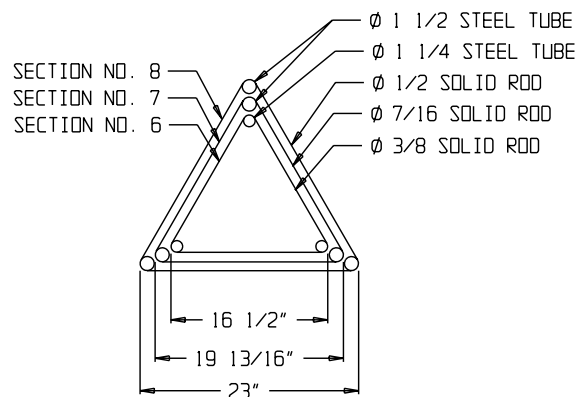

TOWER CROSS SECTION

TOWER DESIGN LOADING

WIND LOAD: 85 MPH W/ 3 SECOND GUST PER ANSI/TIA- 222 REV G

Iri-Ex TOWER CORPORATION
 2183 S. Highland Ave., Sanger, Calif. 93657

TITLE

LM-354HD CRANK UP TOWER